

ST, NST, GCT, NU

中止閥 Stop Valves

NU



ST



NST

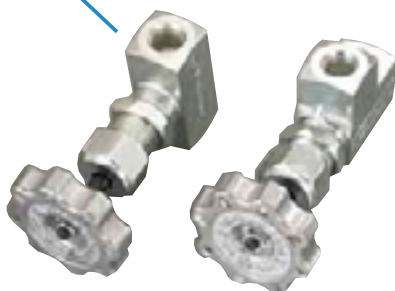

GCT

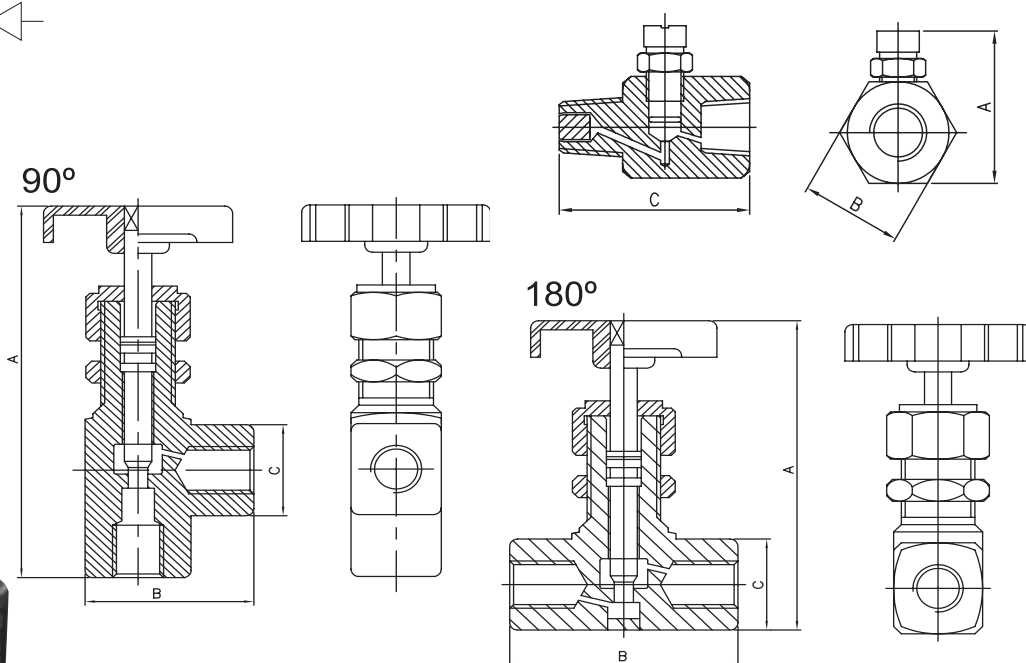
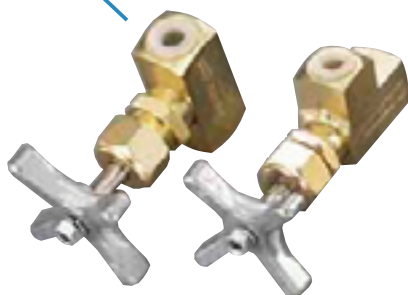

型式編號 Model	管徑 PT	A Fully Open	B	C	流量 Flow L/min	最高壓力 Max pressure kgf/cm ²	重量 Weight kg
ST-02-180°	1/4"	96	49	25	15	210	0.3
ST-03-180°	3/8"	96	49	25	21	210	0.3
ST-04-180°	1/2"	118	64	32	30	210	0.64
ST-02-90°	1/4"	111	42	24	15	210	0.34
ST-03-90°	3/8"	111	42	24	21	210	0.34
NST-02-180°	1/4"	94	51	22	15	250	0.28
NST-03-180°	3/8"	94	51	22	21	250	0.28
NST-02-90°	1/4"	110	37	22	15	250	0.32
NST-03-90°	3/8"	110	37	22	21	250	0.32
GCT-02-180°	1/4"	100	51	22	15	350	0.28
GCT-03-180°	3/8"	100	51	22	21	350	0.28
GCT-04-180°	1/2"	125	65	32	30	350	0.7
GCT-06-180°	3/4"	151	80	38	100	350	1.10
GCT-08-180°	1"	164	95	51	300	350	2.30
GCT-02-90°	1/4"	122	37	22	15	350	0.32
GCT-03-90°	3/8"	122	37	22	21	350	0.32
NU-02	1/4"	32	21	43	0.5	210	0.11
NU-03	3/8"	34	23	45	1	210	0.16
NU-04	1/2"	38	27	50	2	210	0.2