

CV防逆閥 In-Line Check Valves(管式)

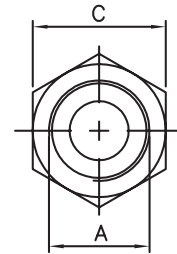

型式編號 Model	A 口徑 PT	B m/m	C m/m	流量 Flow L/min	最高壓力 MAX Operated Pressure Kgf/cm ²	作動壓力 Cracking Pressure Kgf/cm ²	重量 Weight kg
CV-03	3/8"	70	23	40	210	A ₁ :0.5 A ₂ :5	0.18
CV-04	1/2"	80	29	60			0.31
CV-06	3/4"	90	35	100			0.48
CV-08	1"	113	46	150			1.07
CV-10	1 1/4"	133	53	200			1.75
CV-12	1 1/2"	133	65	280			2.60
CV-16	2"	154	71	400			3.12

CE防逆閥 In-Line Check Valves(管式)

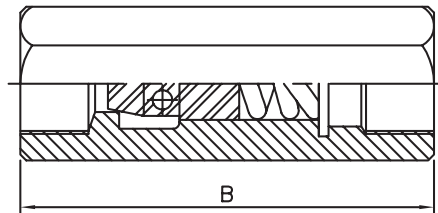
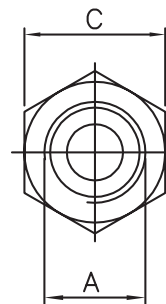
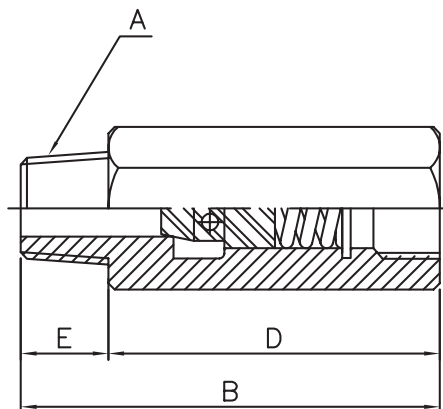

型式編號 Model	A 口徑 PT	B m/m	C m/m	D m/m	E m/m	流量 Flow L/min	最高壓力 Max Operated Pressure kgf/cm ²	作動壓力 Cracking Pressure kgf/cm ²	重量 Weight kg
CE-03	3/8"	70	23	56	13	40	210	A ₁ :0.5 A ₂ :5	0.14
CE-04	1/2"	80	29	65	15	60			0.24